

Design for In-System Serial Programming (ISSP)TM

By: Mark Hastings

Associated Project: No

Associated Part Family: CY8C25xxx, CY8C26xxx

Summary

This Application Note discusses how to design an application to enable In-System Serial Programming using either the Device Reset or Device Power Cycle programming method.

Introduction

PSoCTM devices can be programmed after they have been installed in a system. This allows the PSoC microcontroller to be programmed later in the manufacturing flow or reprogrammed in the field at a late date. PSoC Designer supports two In-System Serial Programming (ISSP) methods: Device Reset and Device Power Cycle programming.

System Configuration

To perform in-system programming the following is required:

- Windows 98, NT, or 2000
- PSoC Designer version 2.16 or later
- Cypress Microsystems ICE
- ICE pod cable
- YProgrammer
- Cable to connect programming pod to target system

See [Figure 1](#) for connection scheme.

The user provides the cable that connects the programming pod to the target board. A five pin, 0.1"-spaced connector is available on the YProgrammer. The connector on the target board can be any connector that meets the needs of the designer. In some cases programming may be performed through test points that are probed by a test fixture connected to the programming pod.

There are five signals in the programming connector, including power. The programming signals are:

Pin	Name	Description
1	V _{CC}	ICE power (connected only in Device Power Cycle mode)
2	GND	System ground
3	X _{RES}	Reset signal (dependant on selected programming method)
4	SCLK	Programming clock signal (P1[1]/XTALIn/SCLK)
5	DATA	Programming data signal (P1[0]/XTALOut/SDATA)

V_{CC} from the ICE is capable of supplying about 300 mA and should only be connected when using Device Power Cycle programming. If the V_{CC} pin is connected to systems that consume more than 300 mA, the ICE may be damaged.

Currently, all PSoC parts, except the 8-pin DIP package, include all five signals. The 8-pin DIP package does not have an X_{RES} pin. These parts still may be programmed in-circuit, but the procedure is slightly different, as detailed in [Configuring Programming Method](#). If the external 32 kHz crystal is used, the programming connections to ports P1[0] and P1[1] need to be kept as short as possible to minimize noise

susceptibility of the oscillator. The total capacitance on each side of the crystal should be close to 25 pF, including the capacitance of the package leads. (See the [CY8C25xx/26xx Family Data Sheet](#) for pin capacitance.) Excessive trace length on these signals could adversely affect the operation of the oscillator. During programming, the 32 kHz oscillator does not operate, so the added load of the programmer is not an issue.

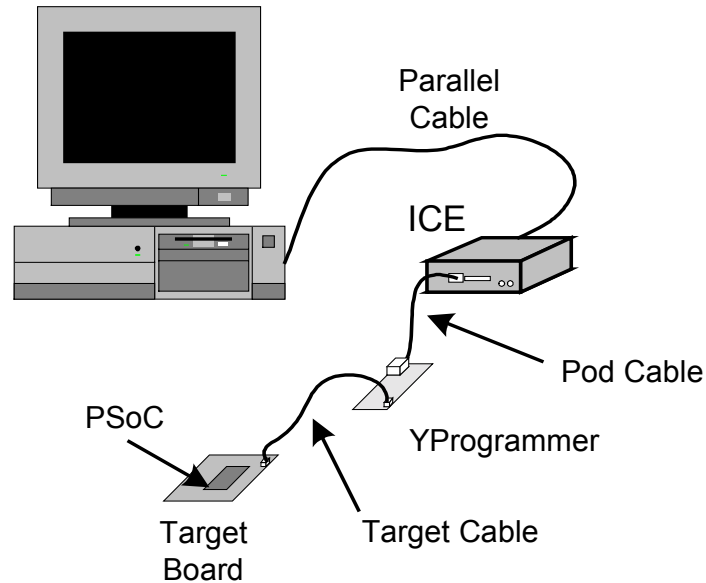

Figure 1: System Configuration

Pin Loading Requirements

The DATA and the SCLK pins each have three functions. These pins are used to program the device, connect an external 32 kHz crystal, and as general-purpose IO pins - if the internal oscillator is used. The equivalent load on these pins should not exceed 120 pF in parallel with a 1-k Ω resistor.

The X_{RES} signal is a single function pin. This signal should be connected directly to the programmer connector. Some designs may drive the X_{RES} signal from another source, such as a system reset, to force reset at a known time. In this case, a resistor may be placed in series with the signal source and the X_{RES} pin. The programmer is then connected on the pin side of the resistor. See [Figure 3](#). This will allow the programmer to overdrive the X_{RES} pin.

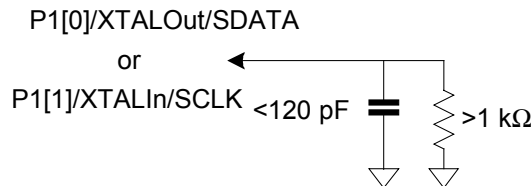

Figure 2: Maximum Load Data and SCLK Pins

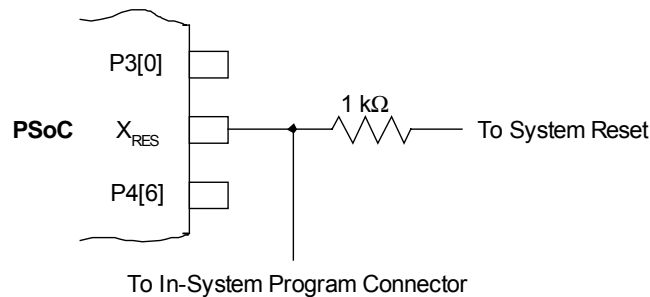

Figure 3: X_{RES} Connection

Configuring Programming Method

Programming is done from within PSoC Designer by selecting either the Device Reset or Device Power Cycle method. The programming method is selected from the menu under **Project >> Settings, Programmer tab**. See [Figure 4](#).

To use Device Reset programming, click “Reset test mode acquisition.” Click “Power cycle test mode acquisition” when using Device Power Cycle programming.

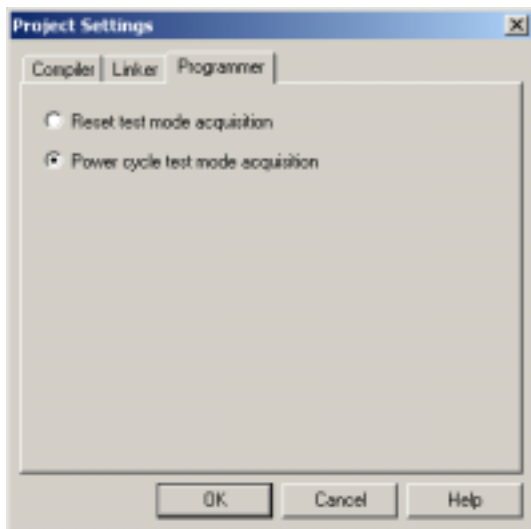



Figure 4: Project Settings Dialog Box

Systems that use packages other than the 8-pin DIP may use either method, but Device Reset programming is preferred. If the 8-pin DIP package is used or the X_{RES} pin is not accessible to the programmer, Device Power Cycle programming must be used.

Device Reset Programming

The Device Reset programming method works on any 3- or 5-Volt system for devices where the X_{RES} pin is available. This method is preferred. When using this method, the V_{CC} signal from the programming pod should not be connected to the target board.

To employ the Device Reset programming method, execute the following procedure:

1. Under the Programmer tab in the **Project >> Settings** dialog box, select “Reset test mode acquisition.”
2. Remove power from target board.
3. Attach target cable between programmer and target board.
4. Apply power to target board.
5. Start device programming and select the Program Part icon .
6. A dialog box will instruct user when programming is complete. Remove target cable.

Device Power Cycle Programming

The Device Power Cycle programming method can only be used in cases where the ICE supplies power to the target board. Power cycling is used to capture the part for programming.

Currently, the ICE is only capable of supplying a V_{CC} of 5 Volts. The components and circuitry on the target must be 5-Volt tolerant to avoid damage during programming.

The power cycle time is approximately 400 mSec. The target must be able to power down and back up in this time or the ICE will not properly be captured. Excessive capacitance on the power supply may cause the power supply to cycle too slowly.

To employ the Device Power Cycle programming method, execute the following procedure:

1. Under the Programmer tab in the Project >> Settings dialog box, select "Power cycle test mode acquisition."
1. Remove power from target board.
2. Attach target cable between programmer and target board.
3. Apply power to target board.
4. Start device programming and select the Program Part icon 
5. A dialog box will instruct user when programming is complete. Remove target cable.

Troubleshooting

If an error occurs during programming, verify all connections. Also, verify that the electrical loading on the SDATA, SCLK, and XRES signals do not exceed the specified maximum ratings.

If using the Device Power Cycle programming method, verify that the target board does not require more than 300 mA. For larger systems that require more than 300 mA, it may be possible to use the V_{CC} signal from the ICE to control the power supply on the target board.

See [Appendix 1](#) and [2](#) for pod and programmer images and programmer schematic.

Note: The standard 28-pin pod used for emulation may be used instead of the YProgrammer module. Rev. D Pods do not support Device Reset programming as shipped from the factory. A standard zero-ohm 0805 resistor or solder short can be added at location R9 to enable this feature.

The **Programming Condition** table below shows what method is supported for the previously described configurations:

Condition	Device Reset	Device Power Cycle	Note
V _{CC} = 4.5 to 5.5V	Yes	Yes	
V _{CC} = 3.0 to 3.6V	Yes	Yes	Device Power Cycle should only be used if target is 5-Volt tolerant.
RST Pin Available	Yes	Yes	
RST Pin Unavailable	No	Yes	
ICE Unable to Supply Power to Target	Yes	No	Target requires more than 300 mA or complex power system.
Use of 8-Pin DIP Package	No	Yes	

Appendix 1: Pod and YProgrammer Images

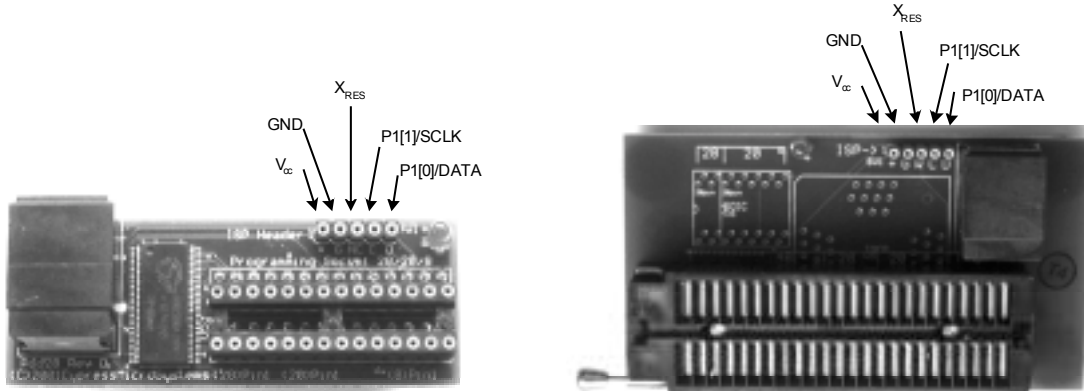

Figure 5: Pod (28-PDIP Rev. D) and YProgrammer (Rev. B)

Appendix 2: Schematic of Programming Pod

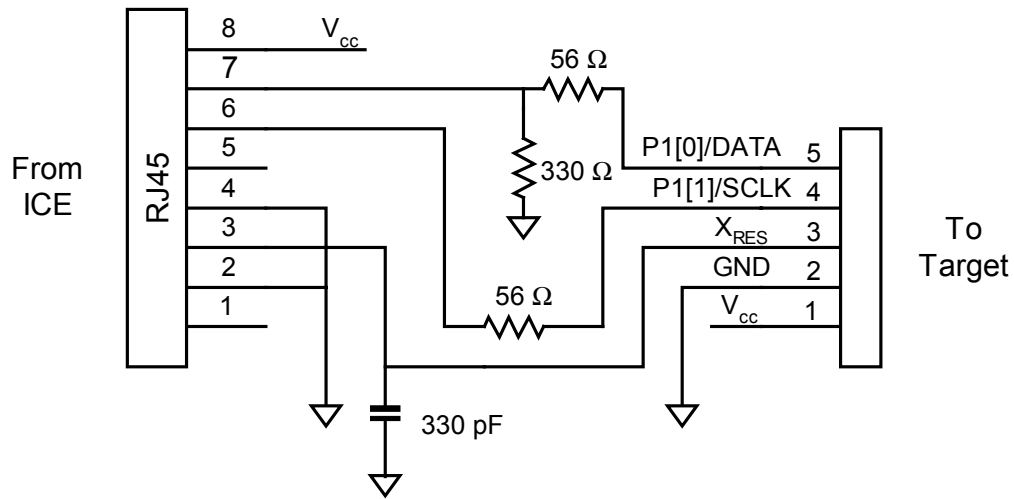

Figure 6: Schematic of Programming Pod

Cypress MicroSystems, Inc.
 22027 17th Avenue S.E. Suite 201
 Bothell, WA 98021
 Phone: 877.751.6100
 Fax: 425.939.0999

<http://www.cypressmicro.com/> <http://www.cypress.com/contacts/> support@cypressmicro.com

Copyright © 2002 Cypress MicroSystems, Inc. All rights reserved.
 PSoC™ (Programmable System on Chip) is a trademark of Cypress MicroSystems, Inc.
 All other trademarks or registered trademarks referenced herein are property of the respective corporations.
 The information contained herein is subject to change without notice.